

SINCE 1980

KRANTI®

**Spiral Water Meter (Bulk) Enclosed Type
IS-2373**

In Size 40mm (1½") to 900mm (36")

**Woltman Type (Removable Mechanism)
ISO 4064/1 (Class B)**

In Size 50mm (2") to 300mm (12")

IS:2373



CM/L-1999288



AN ISO 9001:2008 Co.



SPECIFICATIONS & PERFORMANCE DATA

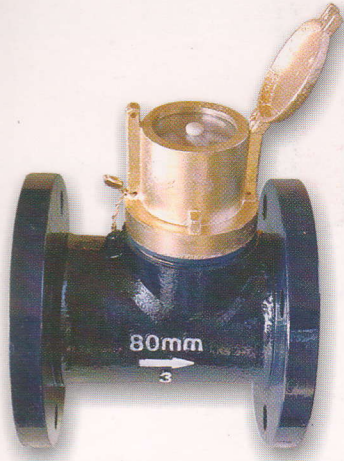

KRANTI®

“SPIRAL” Water Meter (Bulk) Enclosed Type

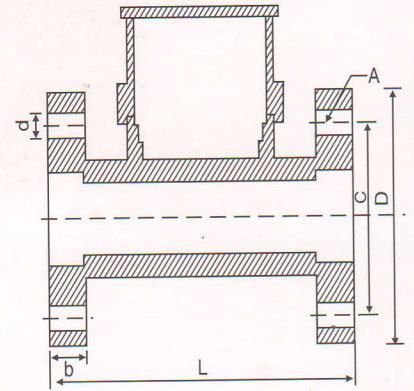

Nominal Size (mm)	40	50	80	100	150	200	250	300	350	400	450	500	600	750	900
Intermediate Flow Litres Per Hour	10000	20000	62000	100000	250000	400000	550000	750000	1000000	1500000	2000000	2500000	3500000	4000000	5000000
Nominal Flow Litres Per Hour	20000	50000	125000	200000	500000	800000	1100000	1500000	2000000	3000000	4000000	5000000	7000000	8000000	10000000
Lower Limit of Flow Litres Per Hour	1000	1660	4160	6660	16660	26660	36660	50000	66660	100000	133300	166600	233300	266666	333300
Minimum Starting Flow Litres Per Hour	400	500	1000	1500	3500	5500	9000	14000	20000	25000	30000	35000	45000	55000	65000
Pressure Test Kg/Cm ²	16	16	16	16	16	16	16	16	16	16	16	16	16	16	16
Minimum Reading in Litres	10	10	10	10	100	100	100	100	100	100	100	100	100	1000	1000
Maximum Reading in Litres	100000000	100000000	100000000	100000000	1000000000	1000000000	1000000000	1000000000	1000000000	10000000000	10000000000	10000000000	10000000000	100000000000	100000000000

FLANGE DIMENSIONS

Nominal Size (mm)	40	50	80	100	150	200	250	300	350	400	450	500	600	750	900
Outside Dia of Flange (D) mm	145	165	200	220	285	340	395	445	505	565	615	670	780	960	1115
Thickness of Flange (b) mm	19	19	21	22	23	24.5	26	27.5	29	30	31.5	33	36	40	44
Dia of Bolt Circle (C) mm	110	125	160	180	240	295	350	400	460	515	565	620	725	900	1050
Number of Holes (A)	4	4	4	8	8	8	12	12	16	16	20	20	20	24	28
Dia of Bolt Holes (d) mm	19	19	19	19	23	23	23	23	23	28	28	28	31	31	34
Total Length (L) mm	170	170	198	240	295	343	443	365	530	535	580	610	645	655

1. Above particulars relate to cold water meters suitable for temperature upto 45°C. 2. As constant efforts are made to improve the designs, details

KRANTI®

**Woltman Type (Removable Mechanism) Water Meter
As per Class B of ISO-4064/1 Magnetic Drive with
Flange Ends, Hermetically Sealed Register**

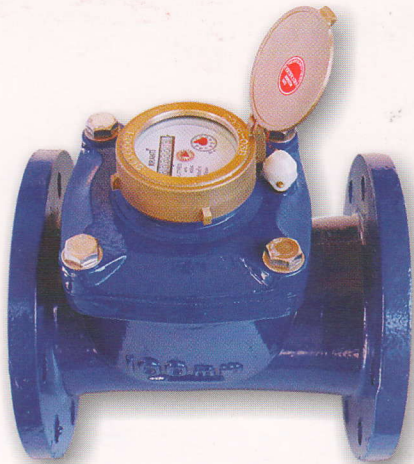

STANDARDS

Conforms to ISO 4064/1, Class B.

APPLICATION

Water Distribution Network
Industrial / Commercial Water Supply
ETP Plant, Pharmaceutical, PWD

FEATURES

- Leak proof and sealed totaliser
- Magnetic drive
- Repairable without interrupting water supply
- Removable mechanism ensures easy maintenance
- Totaliser protected by metallic cover.
- Reliable sensitive metrology and low pressure loss.

OPTIONS

- Hot water meters (<90°C)
- Pulse output water meters.
- Water Meters Suitable for ETP/Dirty Water
- Dirt Box (40mm to 900mm)

METROLOGICAL PERFORMANCE:

Size of meter		Acc(%)	50 mm	65 mm	80 mm	100 mm	150 mm	200 mm	250 mm	300 mm
Minimum flow Q min	m ³ /h	±5	0.45	0.75	1.20	1.80	4.50	7.50	12.00	18.00
Transitional flow Qt	m ³ /h	±2	3	5	8	12	30	50	80	120
Nominal flow Qn	m ³ /h	±2	15	25	40	60	150	250	400	600
Maximum flow Q max	m ³ /h	±2	30	50	80	120	300	500	800	1200
Minimum Reading	m ³		0.002	0.002	0.002	0.002	0.02	0.02	0.02	0.02
Maximum Reading	m ³		999999	999999	999999	999999	9999999	9999999	9999999	9999999
Temperature Suitability	°C		45°C							
Pressure Test	Kg/cm ²		20kg/cm ²							

DIMENSIONS

Size of meter	50 mm	65 mm	80 mm	100 mm	150 mm	200 mm	250 mm	300 mm
Length (L)mm	200	200	225	250	300	350	450	500
Height (H1)mm	78	90	95	108	135	160	198	223
Height (H2)mm	174	171	170	173	200	195	258	262

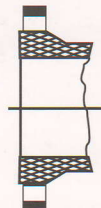
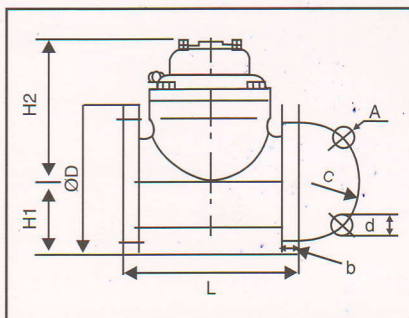

FLANGE SIZE

Size of meter	50 mm	65 mm	80 mm	100 mm	150 mm	200 mm	250 mm	300 mm
Dia Bolt Circle (C)	125	145	160	180	240	295	350	400
Dia Bolt Holes (d)	19	19	19	19	23	23	23	23
Number of Holes (A)	4	4	4	8	8	8	12	12
Outside Dia of Flange (D)	165	185	200	220	285	340	395	445
Thickness of Flange (b)	19	20	21	22	23	24.5	26	27.5

HOT WATER METER / IS 2373 & ISO 4064/1 CLASS B

Applications

- ✓ Sizes available from 40mm to 200mm
- ✓ Measuring of Hot Water upto 100°C
- ✓ Selected material for impeller
- ✓ All parts coming in contact with hot water are of stainless steel.
- ✓ Upper mechanism of meter is multi pointer type
- ✓ All dimensions, specifications and performance data of Hot Water Meter is as per IS-2373

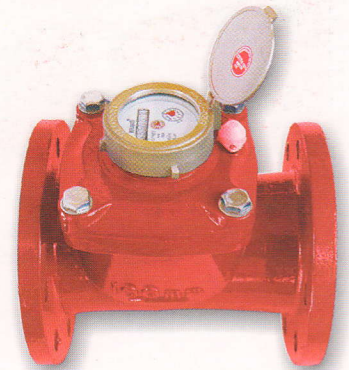

STRAINER (DIRT BOX) "T" TYPE

Applications

- ✓ Sizes available from 40mm to 900mm
- ✓ Provide Strainer before the meter to take better performance of the Meter.
- ✓ Install the Meter and the Strainer in Horizontal position as marked arrow (←) on the Meter.
- ✓ Flanges dimensions of Strainer is as per IS-1538 Part IV & VI



A Product of

B.M. Meters Pvt. Ltd.

Manufactures-Exporters of

Kranti Water Meter - Kushal Flow Meter
B&M Drop Forged Fittings & Forged Flanges

C/96-97, Focal Point Extn, Jalandhar - 144 004 (INDIA)

Tel : 91-181-2603864, 2603865 Fax : 91-181-2603866

Mob. : +91 987 612 8323, +91 987 611 0500

E-mail : bmmeters@yahoo.co.in, kushalflowmeters@gmail.com

Website : www.bmmeters.com